



Temperature insensitive laser for very compact designation function on small platforms

J. Montagne, L. Nguyen, D. Sabourdy, J-F. Lefevre, G. Close, and T. Ledarath

CILAS, 8 avenue Buffon BP6319 F45063 ORLEANS France

Outline

- **Introducing the subject**
- **Possible principles**
- **1st hint : Cancellation of wavelength variation**
- **2nd hint : Cancellation of absorption coeff. variation**
- **3rd hint : No dependency of energy upon absorption**
- **Experiments**
- **Conclusions**

Intro : Compact designators needed

- Collateral damage free military actions Laser designation

- CILAS has a long history in designation and some of its products may be very popular in this field



- Progression towards smaller laser footprint is needed

Designation is meant to be mounted on ever smaller platforms

New designator generation :

- **Highly compact**
- **Low consumption**
- **Short reaction time**
- **Insensitive to external conditions**



And thermal issues are very cumbersome

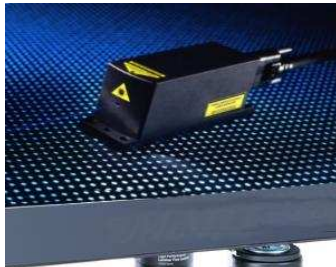

**Usually ones has
a nice tiny laser**

On a bench.

And underneath,..

**additional options
may be needed**



TEC



The trouble is

- We do not want liquid cooling / stabilisation
- We do not want TEC
- However, usually laser needs stabilisation for their pumping semi-conductors
- No stabilisation induces a +/- 5°C acceptance

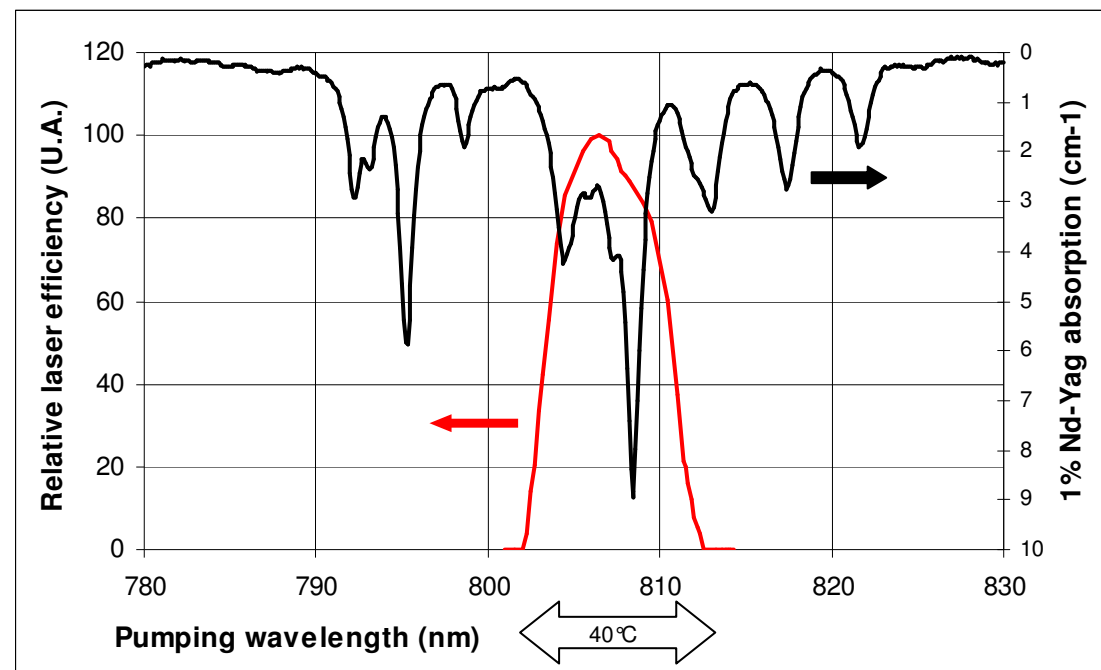

Principles

How to keep energy constant
with varying temperature ?

$$dE/dT = \partial E/\partial \alpha \cdot \partial \alpha/\partial \lambda \cdot \partial \lambda/\partial T$$

Absorption

$$+ \partial E/\partial \sigma_{em} \cdot \partial \sigma_{em} / \partial T$$

Effective cross section

$$+ \partial E/\partial (\partial n/\partial r) \cdot \partial (\partial n/\partial r)/\partial \kappa \cdot \partial \kappa / \partial T$$

Thermal gradients

+.....

Bragg hint

$\partial \lambda / \partial T = 0$: to forbid the diode wavelength shift with T

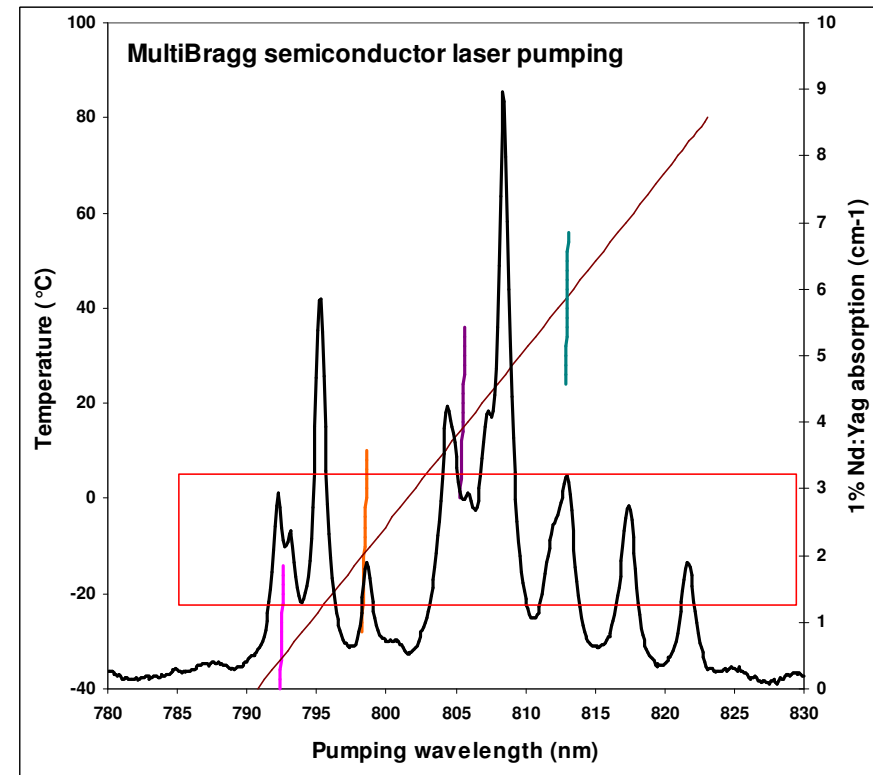
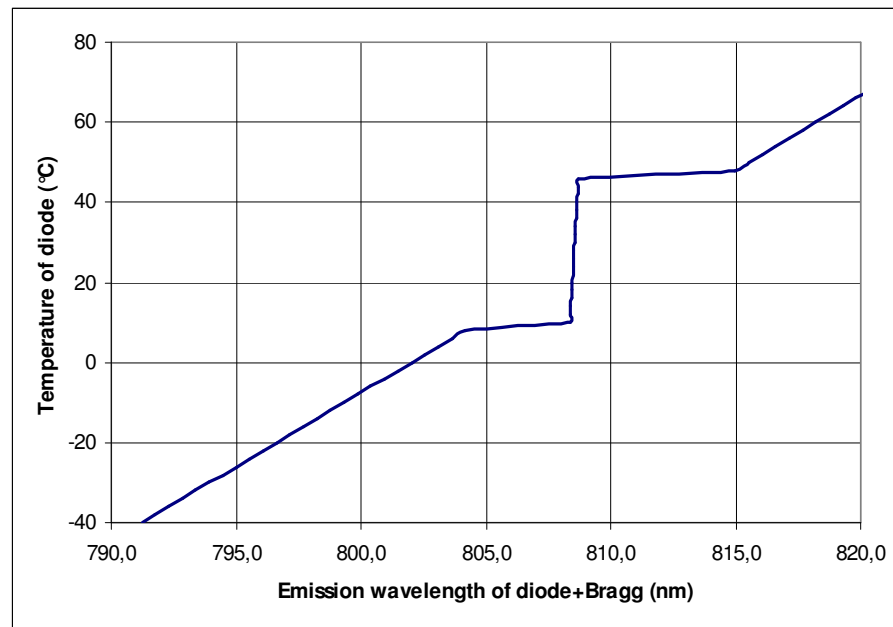
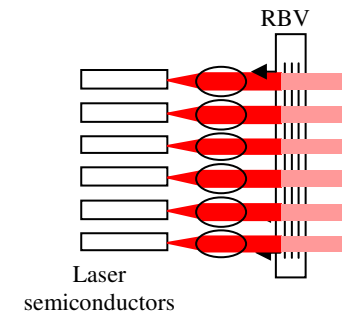

Large spectral range media

$\partial\alpha / \partial\lambda = 0$: Constant absorption coefficient on a large spectral range

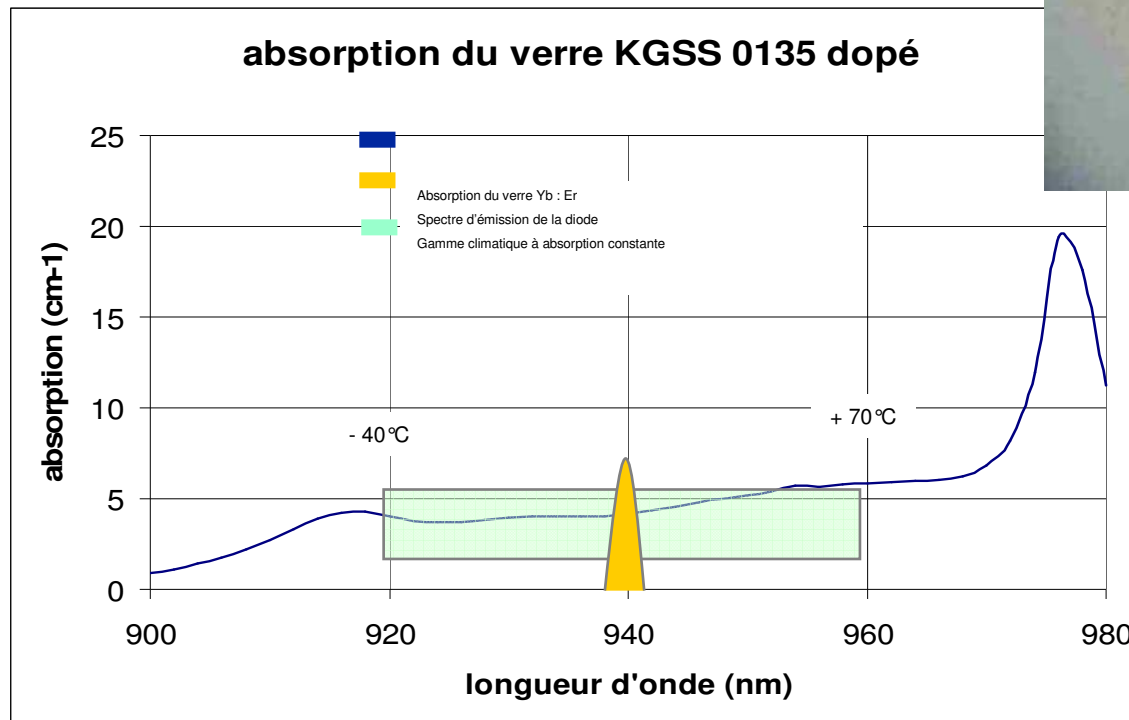

Ytterbium doped media could exhibit such property

Laser for designation - Delta concept

$\partial E / \partial \alpha = 0$: Specific configuration in order to avoid absorption variation effect on stored energy.

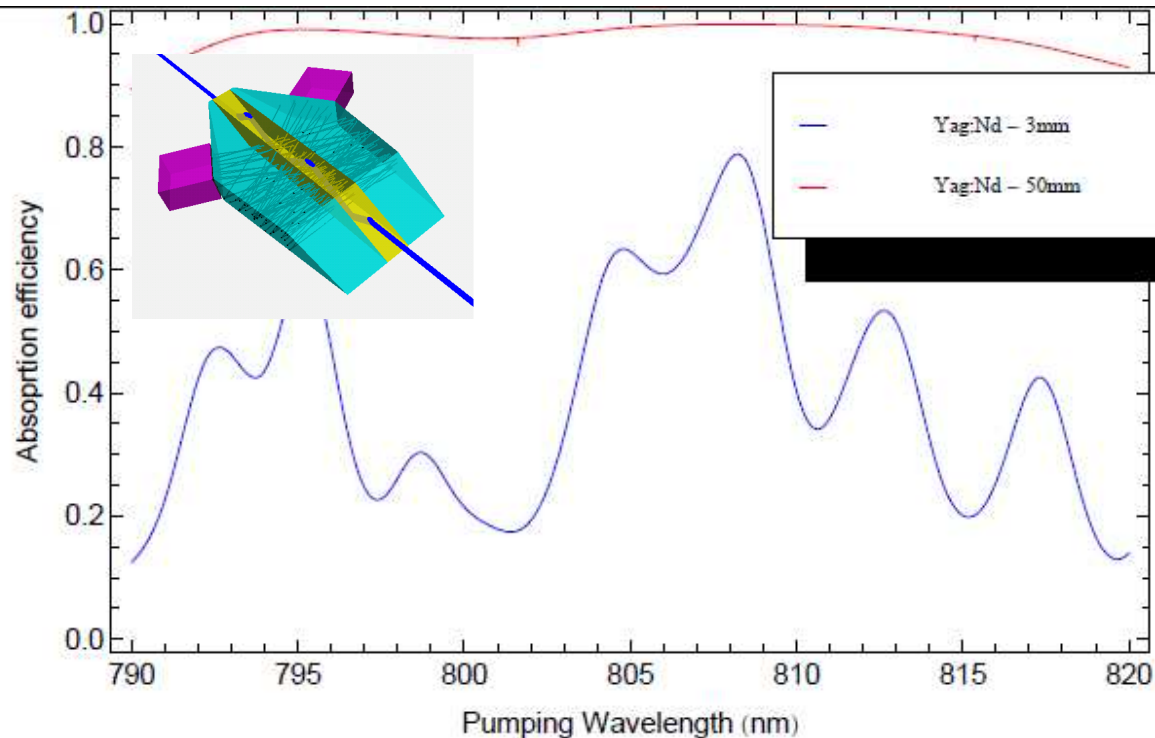

- 1 Auto lens-duct concept
- 1 High optical to optical efficiency
- 1 Compactness
- 1 Large insensitivity to the diode wavelength shift
- 1 Large thermal loading capability

[Crépy, B & All, "Efficient, diode temperature insensitive Nd:YAG hybrid longitudinal/transversal-pumped zig-zag slab laser: delta concept" ASSP 2002 TuC4]

Same principle – Different designs

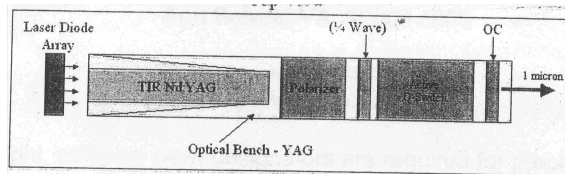

Night Vision and Sensors Directorate & Fibertek : Longitudinal pumping with two recycling arms

[Schilling, B.W & All “Endpumped monoblock laser for broad temperature operation” Appl. Opt. 45(25)]

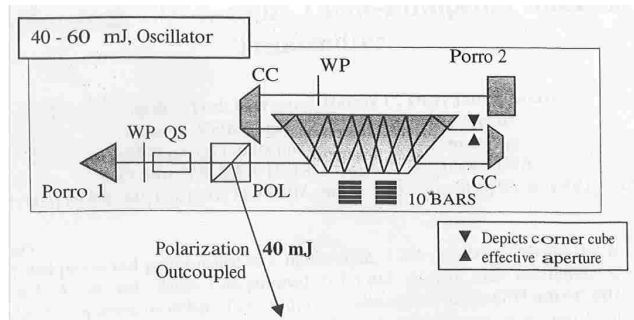

BAE : transverse pumping of a thick slab

[McCarthy, J.C. & All (2005). Athermal, Lightweight, Diode-Pumped, 1 μ m Transmitter. Proc. SPIE Vol.5707, Solid State Lasers XIV, 237 – 242]

Our experiments

2

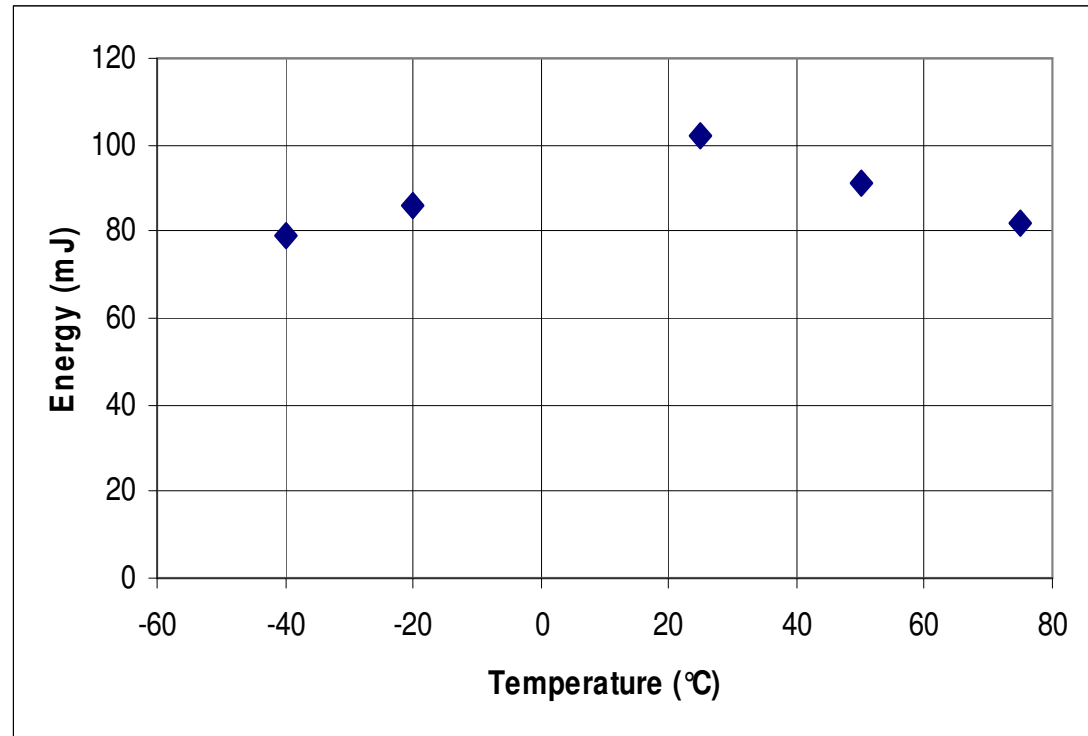
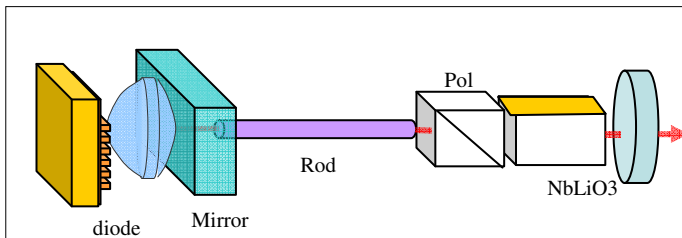

Comparison with present generation

- Energy equivalent
- Power consumption much lower
- No more cooling
- Much better beam quality
- Start time : seconds

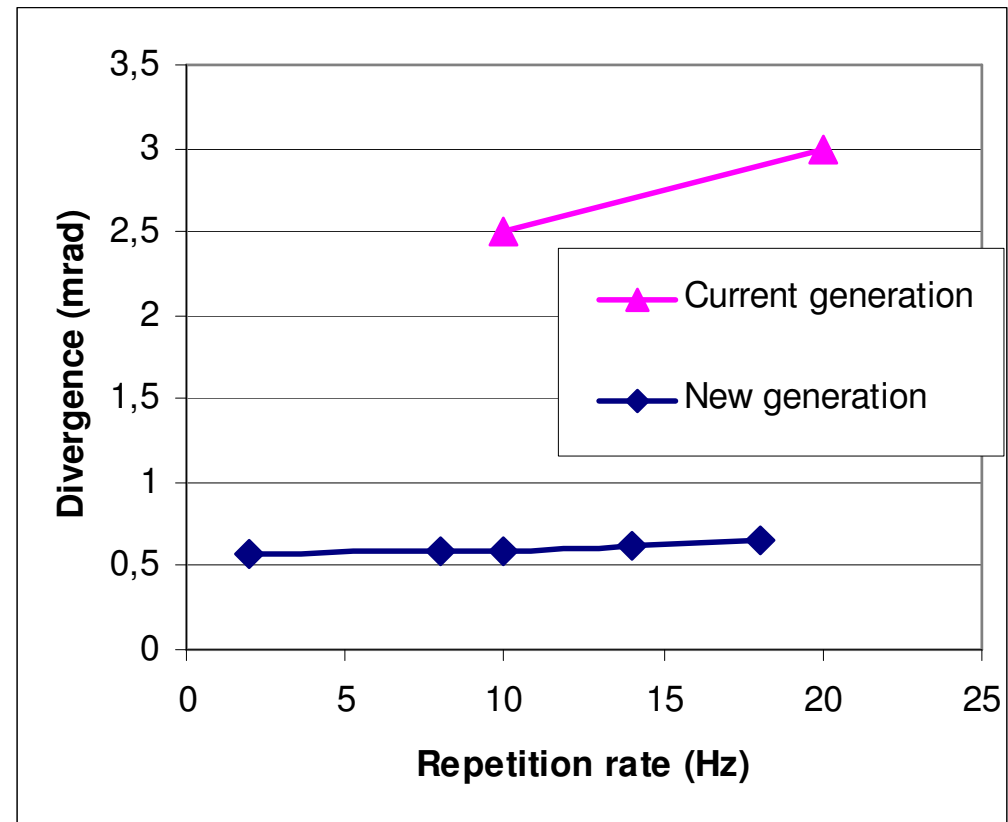

Conclusions

- We developed a new concept, the so-said “temperature insensitive laser”
- This allows further use of laser in optronics, where room or consumption was eliminating this solution